

Ovation 28 Egg Incubator
ADVANCE

Brinsea
Incubation Specialists

Operating Manual

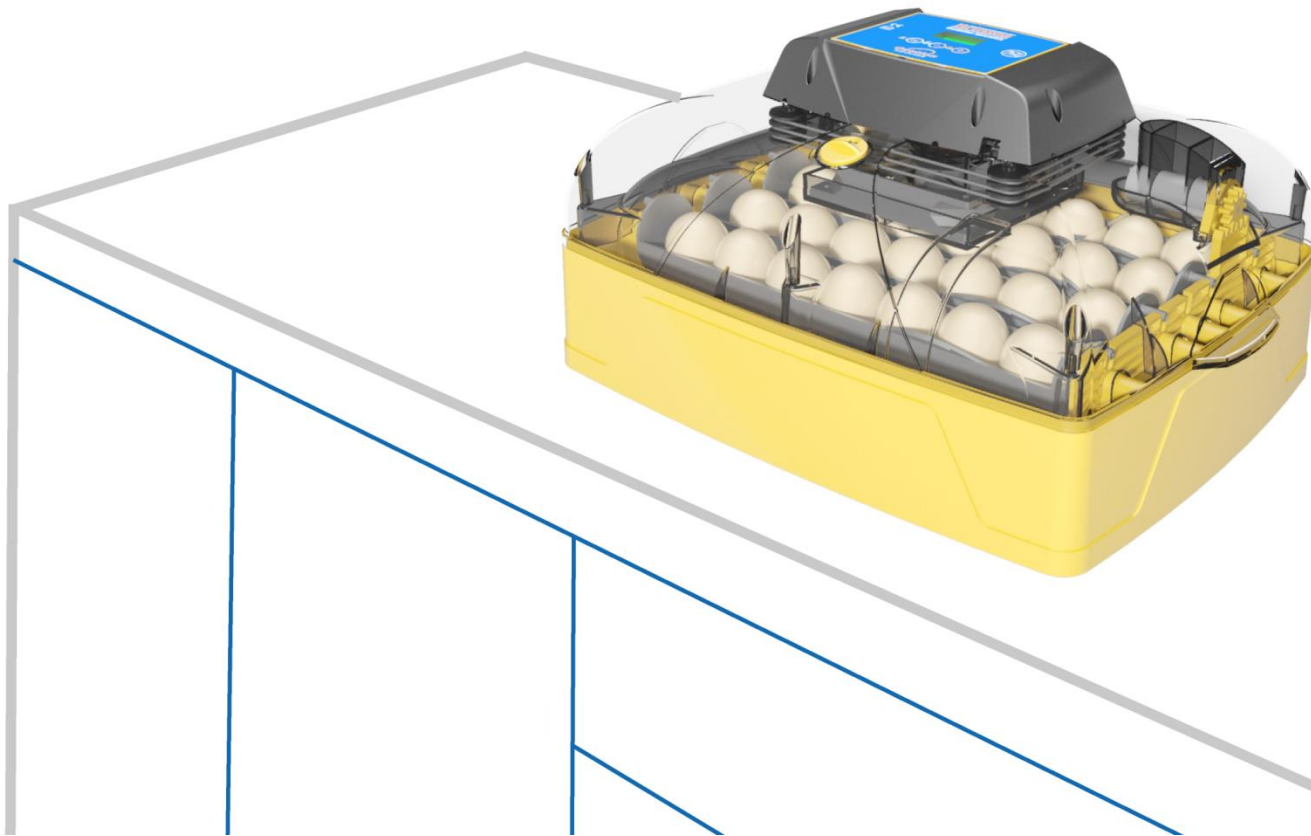



Read the instructions before use!



Do not cover!

Damaged appliances must not be used.

The appliance and its supply cord must be placed in an indoor area not subject to splashes of water or wet conditions and protected from or out of reach of animals.

Repairs must be carried out only by a suitably qualified person.

This appliance must not be used, cleaned or maintained by children or persons with reduced physical, sensory or mental capabilities or lack of experience and knowledge without supervision. Children must not play with the appliance.

Disconnect the incubator from the mains power supply during cleaning. Ensure that all electrical parts are kept dry.

Please read these instructions carefully before setting up your incubator to achieve best results and keep these instructions safe for future reference.

This document includes recommended procedures for successful hatching but incubation involves the control and manipulation of a large number of factors and in certain circumstances different procedures may be necessary.

For more detailed information on all aspects of egg incubation including helpful advice on getting best results please visit our website at www.brinsea.com

Your incubator is designed to allow the user to vary the incubation conditions to suit a wide range of species in different ambient conditions and the specific set-up for every situation is beyond the scope of these instructions.

For more information on incubation and hatching please download our FREE Incubation Handbook:

www.brinsea.com/brochures/BrinseaIncubationHandbook2016.pdf

To register your new Brinsea product please visit www.brinsea.com and follow the link on the right hand side of the home page to qualify for your free 3 year guarantee.

Record your appliance serial number here: _____

- 1 Setting Up Your Incubator** -
- Unpacking 4
- Part Quantities 5
- Assembly 6
- Location & Installation 9

- 2 Product Introduction – Functional Features** 10
- 3 Settings – Control Menu** 11
- 4 Display** 12
- 5 Temperature** 14
- 6 Humidity and Ventilation** 15
- 7 Eggs** 17
- 8 Periodic Incubation Cooling** 18
- 9 Hatching & Cleaning up** 19
- 10 Specifications** 20

UNPACKING

Your incubator has been supplied in protective packaging. Please remove all tape, strapping and packing from the incubator and parts. Retain the carton and packing materials to enable the unit to be repacked.

1: Remove the packaging and lift off the top of the incubator.

2: Remove the card packing inserts and elastic bands from inside the incubator.

3: Check that the electrical supply matches the machine's requirements (marked on the technical label inside the clear top).

1.

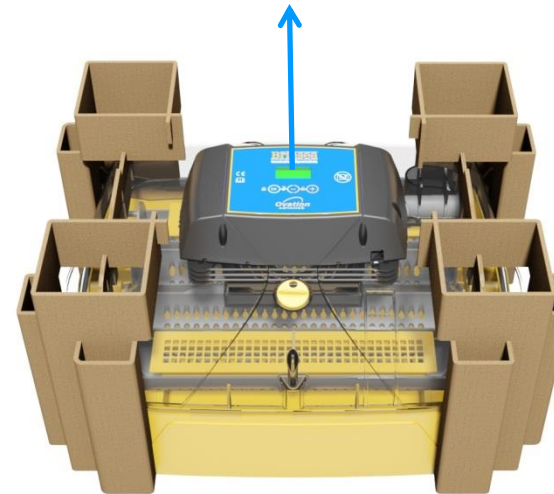

2.

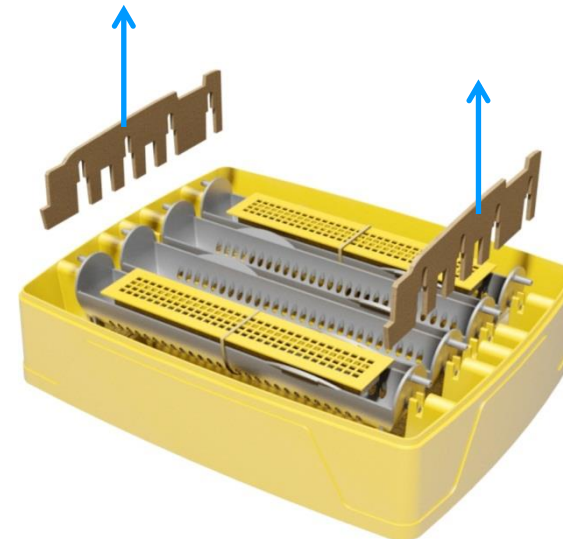



1 SETTING UP YOUR INCUBATOR

PART QUANTITIES

The diagram shows all the parts that have been supplied to you. Ensure you have the correct quantities of each part. If there are any parts damaged or missing please contact your retailer or Brinsea Products (at the address at the end of the document). **Damaged appliances must not be used.**

- 1: Top
- 2: Egg Carriers (4)
- 3: Link
- 4: Water Pan Shutter (1)
- 5: Water Pan Covers (2)
- 6: Base
- 7: Hatching Mat

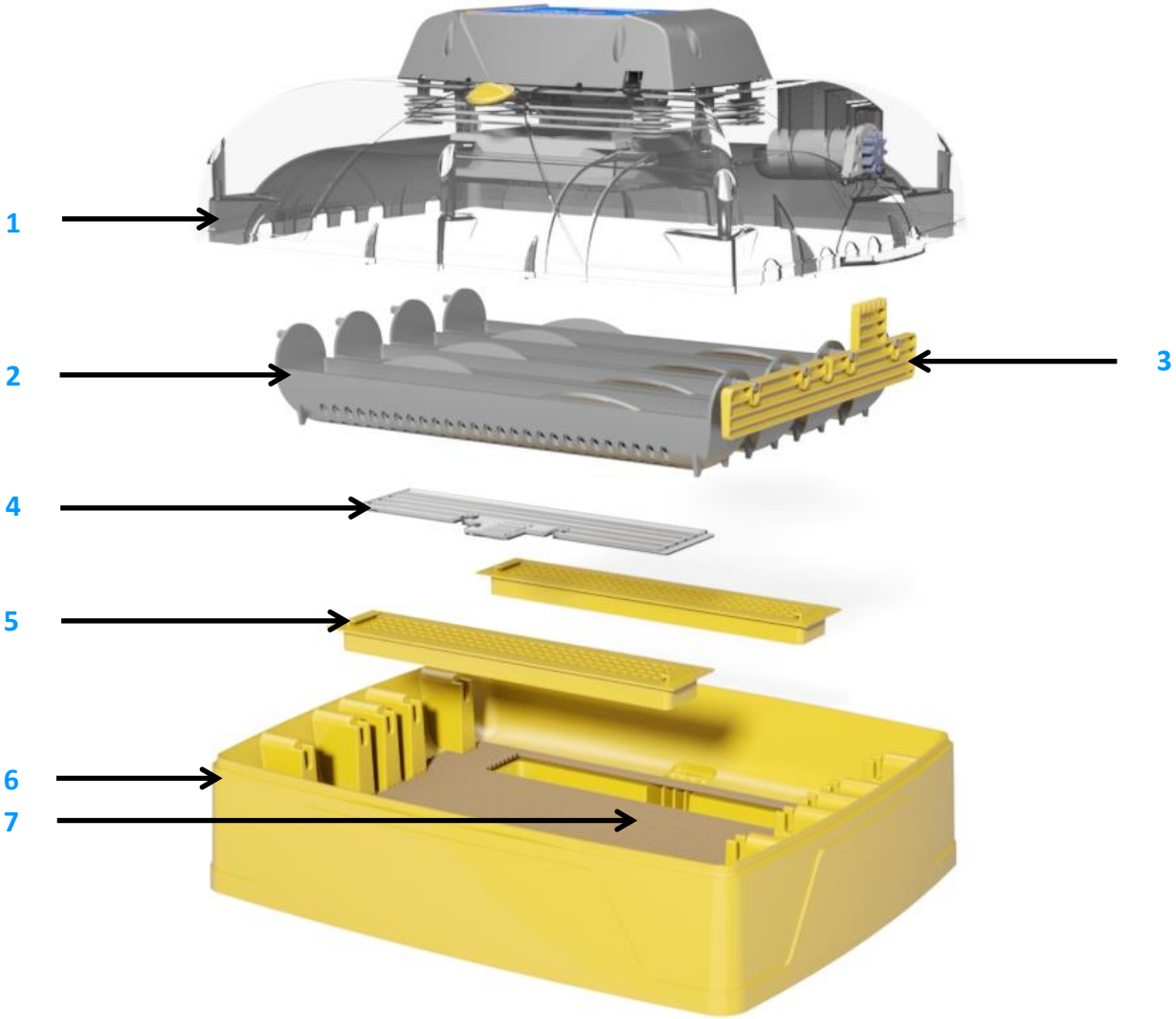

ASSEMBLY

1: Fit the water pan shutter to the water pan cover.

2: Place the water pan covers into their positions in the base.

See section 6 for advice on humidity.

3: Fit the link into its slots ensuring the smooth side is facing inwards.

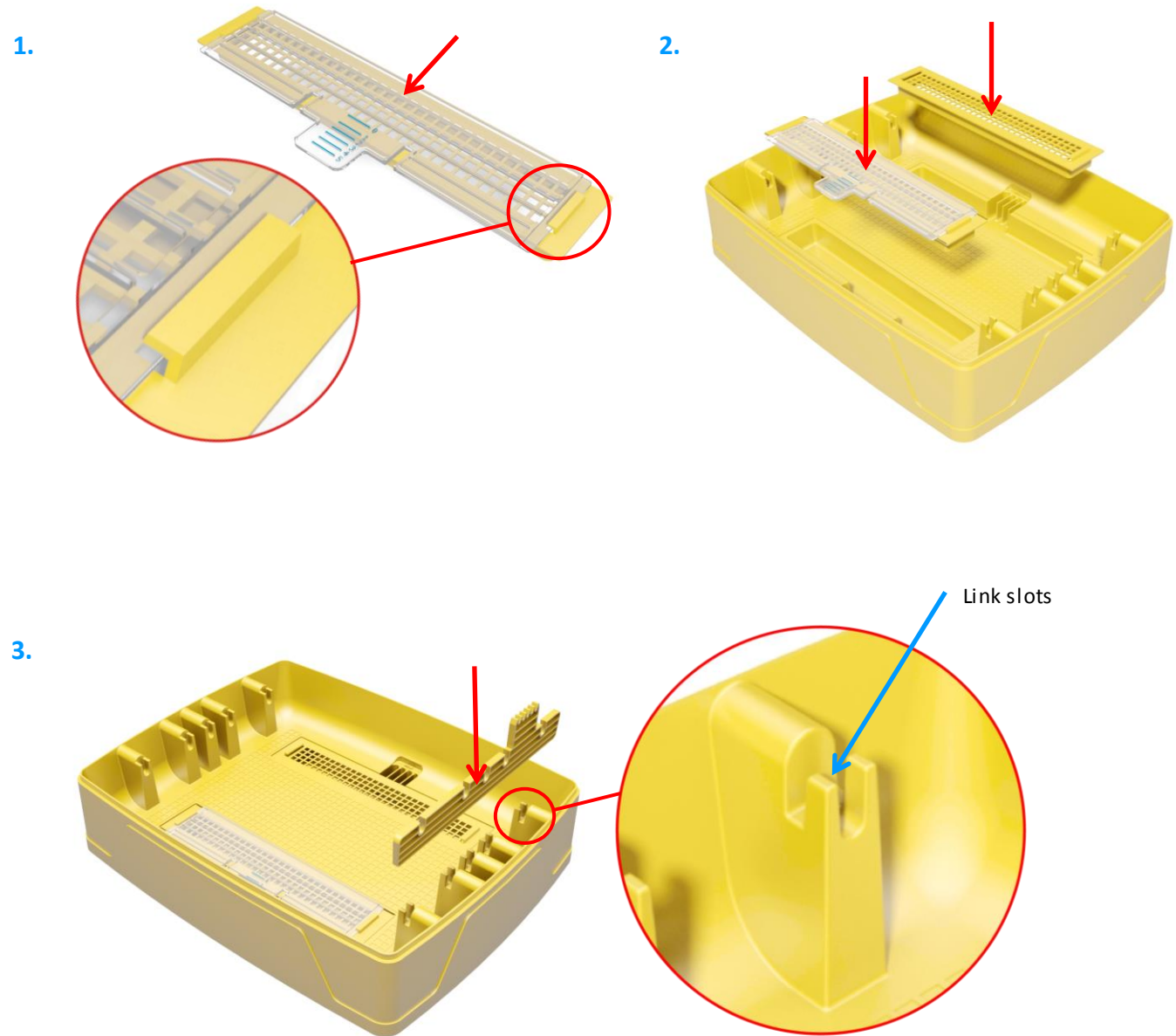

ASSEMBLY

4: Fit the egg carriers into the supports. The pegs must fit in the sockets.

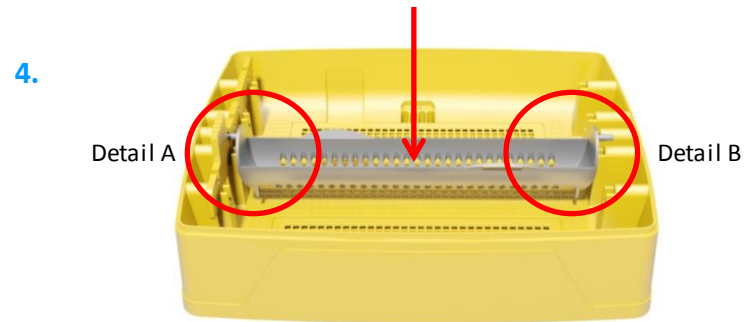

Detail A

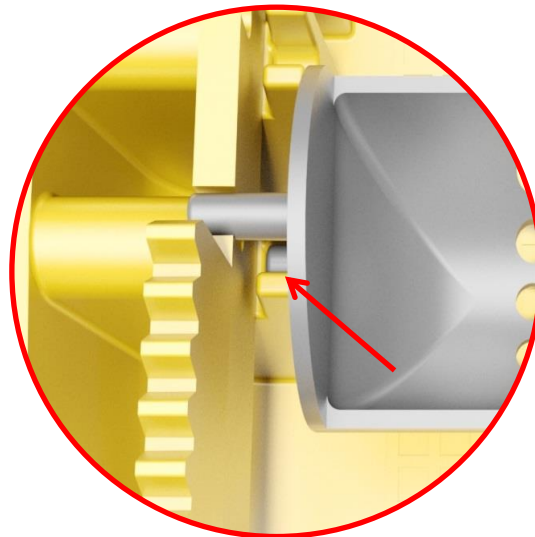

Detail B

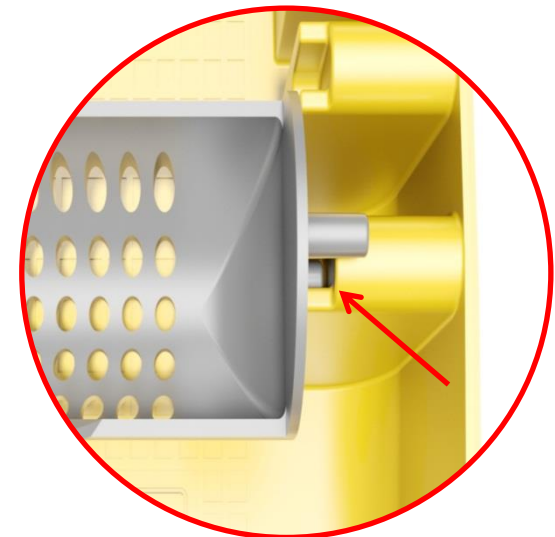

ASSEMBLY

5: Place the top onto the base in the correct orientation. The egg turning motor must sit over the link. Check the top fits flush all the way around the base edge.

5.

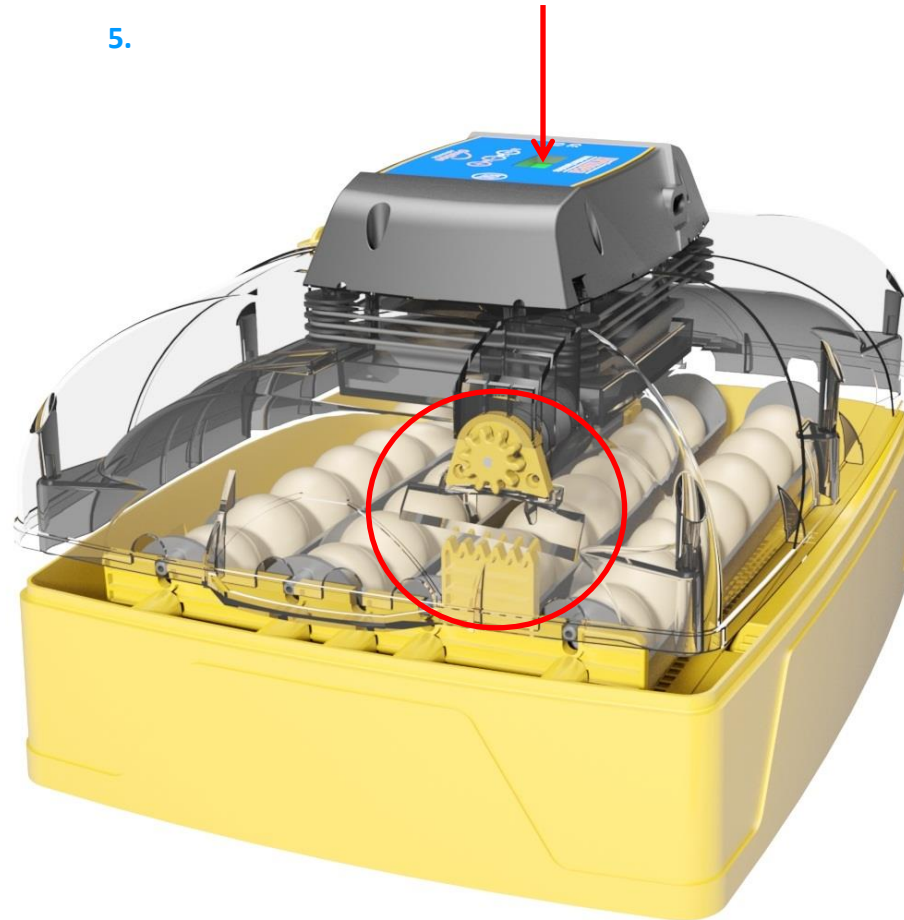

LOCATION AND INSTALLATION

Your incubator will give best results in a heated room free from wide temperature variations and with generous ventilation – particularly if several incubators are running at the same time.

Ensure that the room temperature cannot drop on a cold night. Ideally thermostatically control the room at between 68 and 77°F (20 and 25°C). Never allow the room temperature to drop below 59°F (15°C).

Make sure that the incubator cannot be exposed to direct sunlight and is used on a flat, level surfaced worktop or table, not on the floor. Please ensure the incubator is used on a water resistant surface.

Connect the mains cable to the incubator lid. Ensure the connector is pushed fully home in its socket.

1.

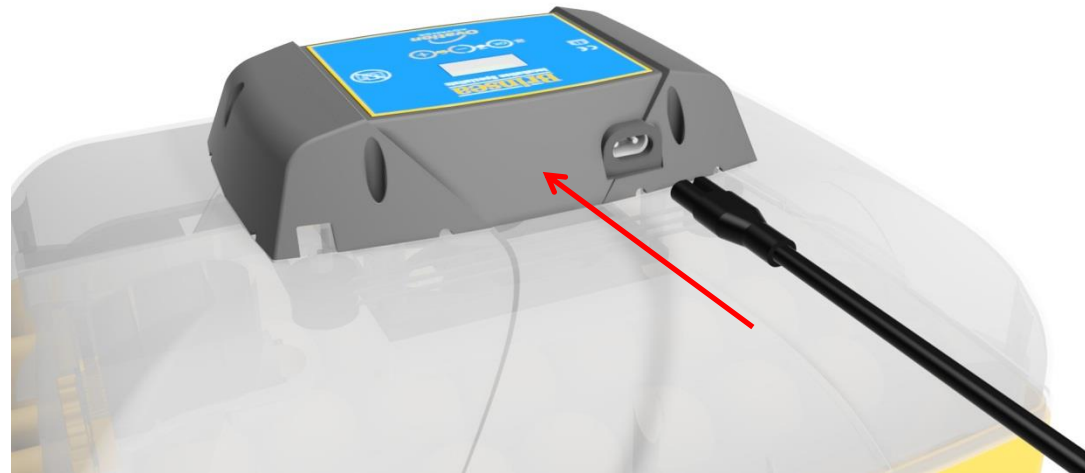

2.



FUNCTIONAL FEATURES

- 1: Digital Display
- 2: Control Buttons
- 3: Adjustable air vent
- 4: Egg Carriers (4)
- 5: Water Pan Shutter

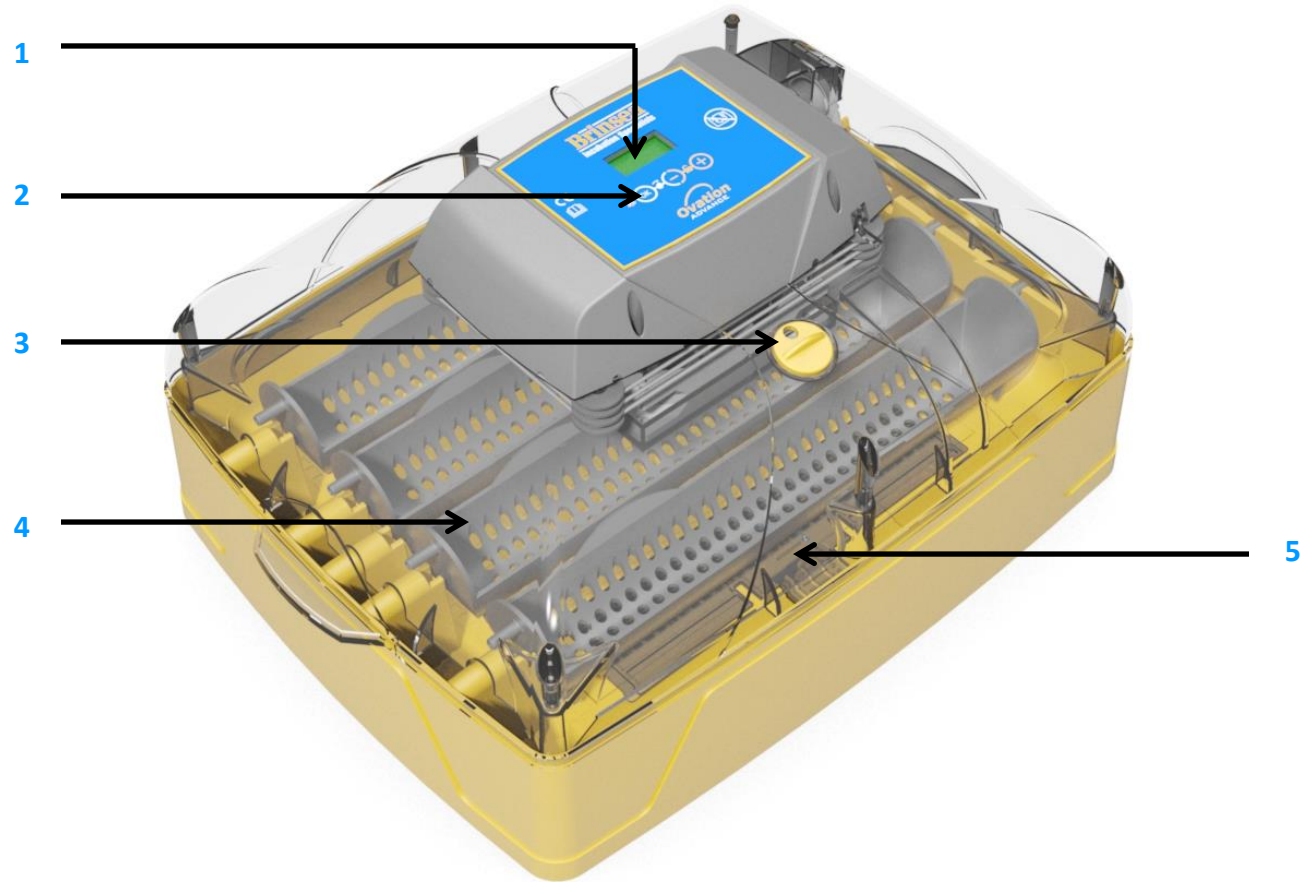

Ovation 28 ADVANCE
3 SETTINGS

CONTROL MENU

The diagram on the right illustrates how to navigate through the control menu. Look at the key below to understand what each button does when pressed.



Press both buttons to unlock the menu.



Select the option / return to the menu.



Go forward one screen / increase the value / display in Celsius.



Go back one screen / decrease the value / display in Fahrenheit.

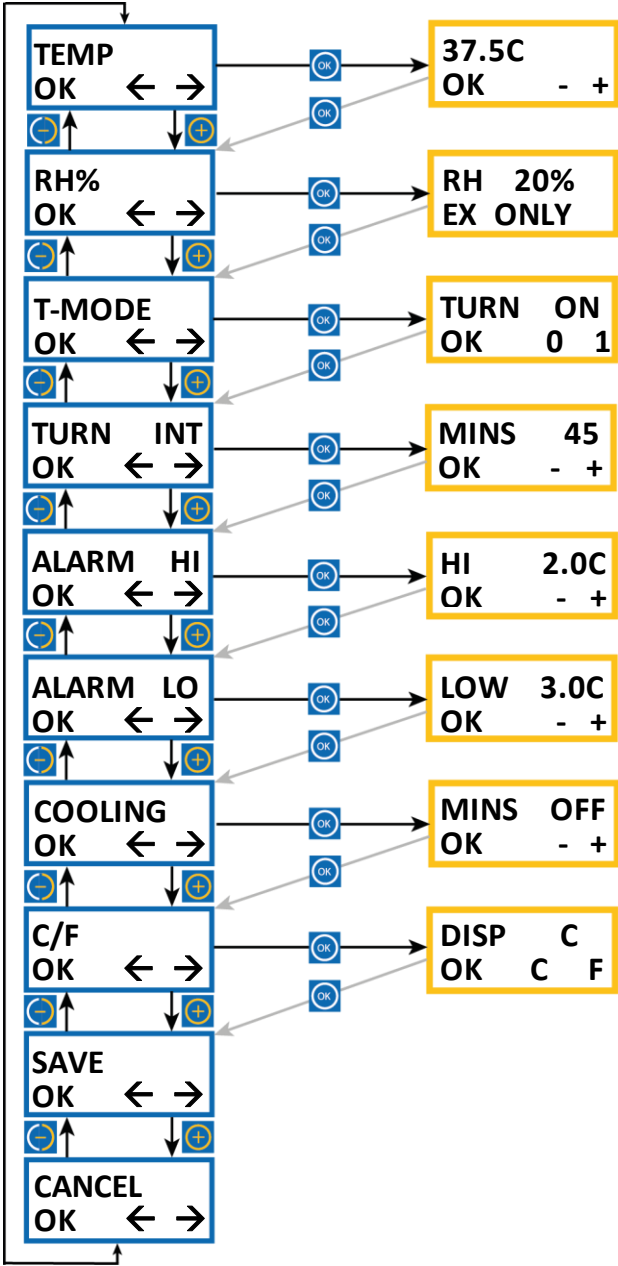

INCUBATION TEMPERATURE
Range 20.0–40.0°C (68.0–104.0°F).
Default 37.5°C (99.5°F). See section 5.

RELATIVE HUMIDITY
(Manually controlled on Advance product)

TURNING MODE
Switches the turnings system on or off.
Default ON.

TURNING INTERVAL
Sets the delay between turns.
Range 5–180 minutes.
Default 45 minutes.

HIGH TEMPERATURE ALARM
Range 1.0–5.0°C (1.8–9.0°F) above set incubation temperature.
Default 2.0°C (3.6°F). See section 4.

LOW TEMPERATURE ALARM
Range 1.0–5.0°C (1.8–9.0°F) below set incubation temperature.
Default 3.0°C (5.4°F). See section 4.

PERIODIC INCUBATION COOLING
Switches heater off for a timed period once every 24 hours. **Do not use before day 7 of incubation or whilst hatching.**
Range 10–360 minutes. Default - OFF. See section 8.

CELSIUS / FAHRENHEIT DISPLAY
Switches all temperature figures between °C and °F.
Default °C. See section 5.

SAVE
All changes are saved. Return to normal operation screen.

CANCEL
All changes are ignored. Return to normal operation screen.

DIGITAL CONTROL SYSTEM

The Ovation Advance control system utilises a highly accurate, individually calibrated sensor for temperature. Be cautious of low cost analogue or digital thermometers when comparing them with the incubator display reading.

Example settings for poultry:

Temperature: 99.5°F (37.5°C)

Humidity: 50-60% RH

Turning interval: 45 minutes (turn off from day 19 and remove egg carriers)

Cooling: OFF

(Add water to one or both water pans and adjust vent to achieve desired humidity.)

(FIG 1)

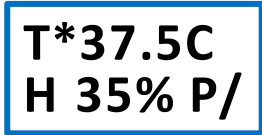

Normal Operation – Temperature, relative humidity and turn system status are continuously displayed.

- The asterisk “*” adjacent to the temperature reading shows when the heater power is on. When warming the asterisk will be continuously on, once warmed up the asterisk will slowly flash as the heater is pulsed to maintain the correct temperature. When reducing the temperature setting the asterisk may go off, this is normal.
- During periodic incubation cooling (see section 8) the asterisk will be replaced by an arrow: “↓”.
- If turning is switched off an “O” flashes at the corner of the display.
- If turning is switched on a line “/” symbol rotates at the corner of the display.

Changing Settings – The Control Menu allows the various settings to be modified and saved. All settings are retained in the event of a power cut.

- To access the Control Menu press the + and – buttons simultaneously to unlock the display. For full details of menu settings please refer to the contents on page 3 and view the relevant sections.

Power Loss Display (FIG 1) -- If power has been interrupted due to a power cut (or when first switching on) a “P” is shown flashing in the corner of the display. Press OK for 2 or more seconds to clear the indicator. If the reason for the power loss is not known check the power cable connections are secure.

- Once the “P” indicator has been cleared, it is advisable to candle eggs a number of times to check for losses.

(FIG 2)

T*39.8C
H 35% H/

(FIG 3)

T*32.1C
H 35% L/

(FIG 4)

T*37.5C
-RM /

(FIG 5)

T*37.5C
+RM /

High Temperature Alarm Display (FIG 2) – If the measured temperature inside the incubator goes up by more than the figure in the ALARM HI screen, the alarm will sound immediately and “H” will be displayed. Press OK to silence the alarm for 30 minutes.

- If the high temperature problem rectifies itself the “H” remains on the display to show this has happened. Press OK to clear the indicator. Check the incubator is not (and has not been) in direct sunlight or too near a heat source such as a room heater. It is advisable to candle eggs a number of times after this event to check for losses.

Low Temperature Alarm Display (FIG 3) – If the measured temperature inside the incubator goes down by more than the figure in the ALARM LO screen, after 60 minutes “L” will be displayed and the alarm will sound. Press OK to silence the alarm for 30 minutes.

- If the low temperature problem rectifies itself the “L” remains on the display to show this has happened. Press OK to clear the indicator. Check the incubator is not (and has not been) in a cold draught and that the room temperature has not dropped significantly. It is advisable to candle eggs a number of times after this event to check for losses.

Low Room Temperature Alarm (FIG 4) – If the calculated room temperature remains too low for optimum results for more than 1 hour a warning is displayed “-RM” and an alarm will sound. Press OK to silence the alarm for 30 minutes.

- If the low temperature problem rectifies itself the “-RM” remains on the display to show this has happened. Press OK to clear the indicator.
- Check the incubator is not (and has not been) in a cold draught and that the room temperature has not dropped significantly. It is advisable to candle eggs a number of times after this event to check for losses.

High Room Temperature Alarm (FIG 5) – If the calculated room temperature remains too high for optimum results for more than 1 hour a warning is displayed “+RM” and an alarm will sound. Press OK to silence the alarm for 30 minutes.

- If the high temperature problem rectifies itself the “+RM” remains on the display to show this has happened. Press OK to clear the indicator.
- Check the incubator is not (and has not been) in direct sunlight or too near a heat source such as a room heater. The eggs themselves create significant metabolic heating at later stages of incubation and may contribute to this if room temperature is high. It is advisable to candle eggs a number of times after this event to check for losses.

SETTING THE TEMPERATURE



1. Press the - and + buttons simultaneously to unlock the Main Menu.



2. Press OK to select the temperature screen and adjust as necessary using the + and - buttons.



3. Press OK to return to the Main Menu and then scroll down to SAVE. Press OK to save the changes.

When reducing temperature, the asterisk may go out while the incubator cools – this is normal. Adjust temperature with care – small differences have large effects on hatching performance.

CHANGING TO FAHRENHEIT



1. Press the - and + buttons simultaneously to unlock the Main Menu.



2. Scroll to the C/F option and press OK to select the C/F display screen.



3. Press the + button to select °F or the - button to select °C.



4. Press OK to return to the Main Menu and then scroll down to save. Press OK to save the changes.

Please Note: Your incubator will be factory set for hen eggs, you may wish to adjust the temperature in the menu to suit the types of eggs you are incubating.

As the incubator warms up and approaches its control setting the 'heater on' asterisk "*" will change from continuously on to flashing. Allow the incubator to stabilise for at least an hour before adjusting the temperature.

	Recommended temperatures:		Typical incubation period:
Hens	99.3 – 99.6°F	37.4 – 37.6°C	21 days
Pheasant	99.6 – 100.0°F	37.6 – 37.8°C	23-27 days
Quail	99.6 – 100.0°F	37.6 – 37.8°C	16-23 days
Ducks	99.3 – 99.6°F	37.4 – 37.6°C	28 days
Parrots:			
Amazons	98.3 – 98.6°F	36.8 – 37.0°C	24-29 days
Macaaws	98.3 – 98.6°F	36.8 – 37.0°C	26-28 days
Love birds	98.3 – 98.6°F	36.8 – 37.0°C	22-24 days
African Grey	98.3 – 98.6°F	36.8 – 37.0°C	28 days
Eclectus	98.3 – 98.6°F	36.8 – 37.0°C	28 days

- Developing embryos are fairly tolerant of short term temperature drops and the user need not be concerned about cooling that occurs when inspecting eggs. Temperatures above ideal can quickly have a serious detrimental effect on hatch rates and must be avoided.
- The Ovation Advance has a built-in temperature alarm which warns of high or low temperatures. See section 4 for details.

UNDERSTANDING HUMIDITY

Short term variations in humidity are not important. The average humidity over the incubation period needs to be near optimum to achieve the ideal weight loss.

High humidity for the day or two of hatching is also important. Beware chronic, excessive humidity.

Typical Humidity:

Generally accepted incubation RH levels for species groups in Ovation 28 incubators:

During incubation:	Poultry	50-60% RH
	Waterfowl	55-65% RH
	Parrots	40-50% RH
Hatching:	All species	60-65% RH

Typical Weight Loss:

Typical ideal weight losses for species groups:

Poultry	13%
Waterfowl	14%
Parrots	16%

For more specific information on particular species' requirements check the relevant literature.

Two factors affect incubation humidity: water evaporation within the cabinet (from eggs as well as from additional water) and levels of ventilation. The water content of the air being drawn through the incubator will also have an effect.

There are two methods available to bird breeders to achieve correct humidity levels:

- 1: Monitor humidity levels and adjust to match published guidelines for different species.**
- 2: Monitor egg weight loss which varies as a direct result of humidity and correct against published weight loss figures for the species. This is the most reliable method and is recommended – particularly where poor hatch rates are experienced or if eggs of high value are being incubated.**

Eggs lose moisture through their shells and the rate of evaporation depends on the humidity levels around the eggs and the shell porosity. During incubation eggs need to lose a fixed amount of water which corresponds to a loss in weight of around 13-16% depending on species. By weighing eggs periodically during incubation it is possible to monitor and, if necessary, correct humidity levels to achieve the correct weight loss.

For more detailed information on all aspects of egg incubation including helpful advice on getting best results please visit our website at www.brinsea.com/brochures/BrinseaIncubationHandbook2016.pdf

ADJUSTING THE RELATIVE HUMIDITY LEVEL

1: To maintain a low humidity level do not add water to either of the pans.

To increase humidity, first add water to the water pan with the sliding shutter and set the sliding water pan shutter to achieve the desired humidity level (0 = lowest to 5 = highest).

To further increase the humidity, add water to the second water pan and remove the sliding water pan shutter from the first water pan as necessary.

2: To fill the water pans take the lid off. Open the sliding water pan shutter if fitted. Carefully pour water into the fill points ensuring you do not fill beyond the "MAX" (as shown in diagram 2).

Humidity levels may be further increased by placing strips of evaporating card or cloth into one or more of the water channels. Evaporating card is available from Brinsea Products.

HATCHING

In all cases the humidity for hatching needs to be high. Because of the short duration involved water/weight loss will not be significantly affected. High humidity is necessary to prevent membranes drying and hardening before the hatch fully emerges. Humidity will naturally increase as the first eggs begin to hatch and internal membranes begin to dry. This effect is in addition to the increased area of water evaporation from the water channels.

During hatching the high humidity levels will fall dramatically when the lid is opened and will take some time to build up. Resist the temptation to lift the lid frequently – leave for at least 6 hours between inspections.

1.

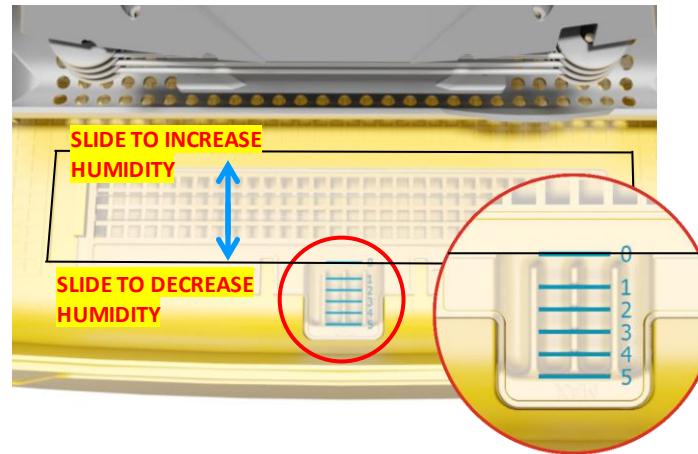

2.

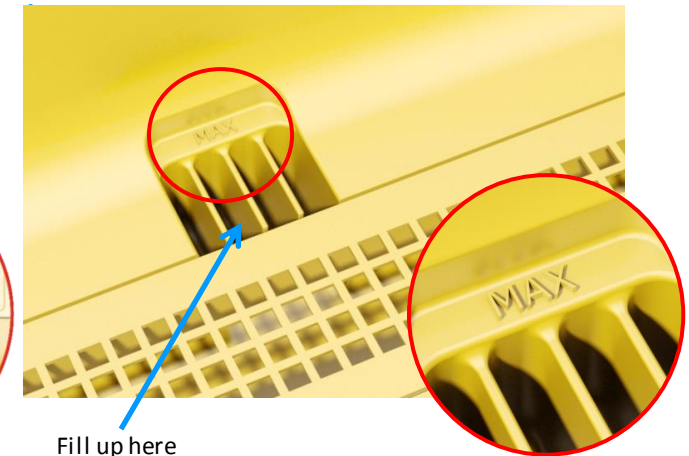

In practice the minimum and maximum levels of humidity achievable in an incubator depend upon several factors including the ambient conditions in the incubation room. You may need to allow 24 hours for humidity to fully stabilise after making changes.

If you cannot achieve the relative humidity level required consider these notes:

Humidity will not go low enough

- Open the adjustable air vent fully to help.
- Slide the water pan shutter to the lowest setting (0).
- Remove all water.
- A lower limit will be determined by the moisture content of the ambient air, particularly in warm humid conditions. This can only be countered by dehumidification of the room air outside the incubator with a proprietary dehumidifier but is rarely a problem in practice.



Close the vent to increase humidity or open the vent to decrease humidity.

Humidity will not go high enough

- Close the adjustable air vent to its minimum setting to help. Remove the water pan shutter. Fit evaporating card strips available from Brinsea or your stockist.

Condensation

It is normal for some condensation to occur on the cooler exposed parts of the clear top. This natural phenomenon is not a hazard or a problem for incubation but may indicate the room is cooler than optimum.

SETTING THE TURNING OPTIONS



1. Press the - and + buttons simultaneously to unlock the Main Menu.



2. Press + to scroll to the TURN 0/1 option.



3. Press OK to select the turning mode screen and use the + and - buttons to set to ON or OFF as required.



4. Press OK to return to the Main Menu. The TURN INT option will now be displayed. Press OK to select the turn interval screen and use the + and - buttons to set the delay between turns in minutes as required.



5. Press OK to return to the Main Menu and then scroll down to SAVE. Press OK to save the changes.

STORING, SETTING AND TURNING EGGS

Ensure that you store eggs in cool, damp conditions. Most species may be safely stored for up to 14 days before serious reductions in hatch rates are likely. Daily turning of stored eggs also helps maintain hatchability.

Discard cracked, mis-shaped and heavily soiled eggs (if possible). Only wash soiled eggs using a branded egg wash solution such as Brinsea Incubation Disinfectant Concentrate following the manufacturer's instructions. It is essential to wash eggs in solution which is significantly warmer than the egg. Bear in mind that all solutions will remove the outer cuticle from the egg as well as the dirt and may leave the egg at greater risk from bacterial contamination in the future.

The Ovation 28 Advance is designed to accommodate eggs of different sizes from pheasant to duck eggs or larger/ smaller eggs using the alternative egg carrier.

Before setting eggs ensure that the incubator has been running for several hours and has stabilised at the correct temperature.

Set the eggs in the egg carriers provided. The eggs need to be set lying flat or with their pointed ends facing down. Switch the turning system on. A revolving line symbol “/” should be shown in the corner of the display.

Check the water level every 2 days or so and temperature daily. Candle the eggs after 1/3rd of the incubation period has elapsed to reject clear, infertile eggs. Remember to stop the turning 2 days before the eggs are due to hatch.

Pointed ends of eggs facing down

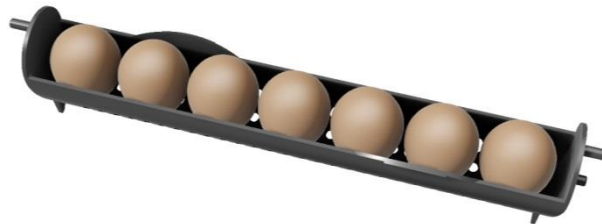

Eggs lying flat

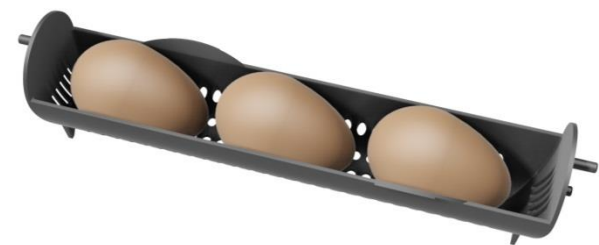

Ovation 28 ADVANCE
8 PERIODIC INCUBATION COOLING

SETTING THE COOLING PERIOD

The cooling function is not essential. It's an optional feature that may be adjusted for breeders wishing to experiment. The factory default is set to "cooling OFF". **Do not use before day 7 of incubation or whilst hatching.**



1. Press the - and + buttons simultaneously to unlock the Main Menu.



2. Press the + button to scroll to the cooling option.



3. Press OK to select the cooling screen. Use the + and - buttons to select OFF or 10 to 360 minutes of cooling.



4. Press OK to accept the figure and then scroll to SAVE and press OK to save the changes.

BACKGROUND INFORMATION ON PERIODIC COOLING

The precise details of which days and what cooling period each days should be used for best effect are not known. Brinsea have assessed the available research and suggest that poultry, water fowl and game bird eggs have a 30 minute daily cooling period from day 7 through to 2 days before eggs are due to hatch (the same point that automatic turning would normally be stopped).

COOLING IS NOT RECOMMENDED FOR PARROTS AND BIRDS OF PREY BECAUSE THE RESULTS OF COOLING HAVEN'T YET BEEN ESTABLISHED. For further details please visit the Brinsea website at www.brinsea.co.uk/cooling

HOW IT WORKS WITH YOUR INCUBATOR

- The periodic cooling feature turns the incubator's heater and low temperature alarm off for a selectable period but keeps the fan running. After the cooling period is complete the incubator reverts to normal temperature and the alarm is automatically reset.
- Each cooling period starts at approximately the same time each day (24 hours between start times). The first cooling period will start 24 hours after the incubator was last switched on. If there is a power interruption the 24 hour delay starts again.
- During the cooling period the heater asterisk goes off and an arrow "↓" is displayed. When the cooling period ends the asterisk is shown and the incubator warms to incubation temperature. The time taken to return to incubation temperature depends on the room temperature and may take 30 or more minutes.

Ovation 28 ADVANCE

9 HATCHING & CLEANING UP

HATCHING

1: If hatching in the Ovation 28: Two days before the hatch is due, remove the top, egg carriers and their link. Remove the water pan shutter and water pan covers.

2: Insert the hatching mat, ribbed side up. Re-fit the water pan covers (without the water pan shutter) over the hatching mat. Lay the eggs directly onto the mat. Don't re-use hatching mats. Replacements are available from brinsea.co.uk, brinsea.com or your local stockist (product code AF014).

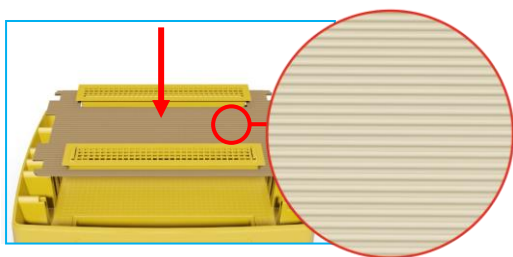

3: Put the top back on.

4: Turning must be switched to OFF in the control menu. Hatching humidity levels need to be high (see section 6 above).

When most eggs have hatched (12 to 48 hours after the first egg hatches) remove the hatchlings to a brooder. The Brinsea EcoGlow 20 and 50 are ideal for poultry and waterfowl etc. The Brinsea TLC-40 and TLC-50 Brooders are recommended for exotics.

During hatching the high humidity levels will fall dramatically when the lid is lifted and will take some time to build up. Resist the temptation to open the incubator frequently – leave for at least 6 hours between inspections.

CLEANING UP

IMPORTANT:

DISCONNECT THE INCUBATOR FROM THE MAINS POWER SUPPLY DURING CLEANING.

ENSURE THAT ALL ELECTRICAL PARTS ARE KEPT DRY. DO NOT IMMERSER THE INCUBATOR TOP.

NEVER WASH THE BASE, EGG CARRIERS, COVERS OR CABINET PARTS IN LIQUIDS OVER 120°F (50°C). DO NOT USE A DISHWASHER TO CLEAN ANY PARTS OF THE INCUBATOR.

Following each hatch in the Ovation 28 Advance remove and wash the egg carriers, link and base in Brinsea Incubation Disinfectant Solution and then rinse thoroughly. Use a vacuum cleaner and soft brush to remove dust from the fan guard. Wipe all other internal surfaces with a cloth made damp with the solution and then wipe off with a cloth made damp with clean water. Ensure that the instructions supplied with the fluid are followed.

If a separate hatcher is used the procedure above should still be followed every two months.

The exterior of the incubator may be cleaned with a damp cloth. Avoid allowing any moisture to get inside electrical housings.

If after extended use more thorough cleaning within the top of the appliance is required, please visit www.brinsea.co.uk for information on how this may be safely performed.

ALWAYS CLEAN THE INCUBATOR BEFORE STORAGE AND ENSURE THAT THE UNIT IS TOTALLY DRY INSIDE AND OUT. ALLOW IT TO RUN FOR 24 HOURS WITH NO WATER INTO ENSURE IT IS THOROUGHLY DRY.

TROUBLE-SHOOTING AND CALIBRATION

In case of failure first check that the mains power supply is working and that the mains cable connector is fully engaged in the socket on the control enclosure.

The digital temperature and humidity display is individually calibrated during manufacture but may be re-calibrated if required. In the unlikely event that your hatching success makes you doubt the temperature or humidity calibration of your machine please contact your distributor or Brinsea directly at sales@brinsea.com for further information and advice.

Ovation 28 ADVANCE

10 SPECIFICATIONS

Ovation 28 MAXIMUM SETTING CAPACITIES:

Egg size	Typical capacity
Quail	66
Pheasant	57
Hen	28
Duck	28
Goose	9

Dimensions: 17.6" x 13.1" x 8.8"
(447mm x 332mm x 223mm)

Weight: 6lb 14oz (3.13 Kg)

Power Consumption:

Incubator maximum 60 Watts
(typical average) 30 Watts

Electrical Supply: 230v 50Hz or 110V 60Hz
(as ordered)

Brinsea Products Inc., 704 N Dixie Ave.,
Titusville, FL 32796-2017 USA.

Phone (321) 267-7009

Toll Free 1-888-667-7009

Fax (321) 267-6090

e-mail sales@brinsea.com

website www.brinsea.com

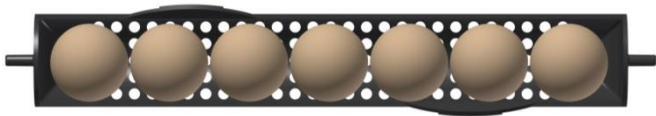

7 hen eggs in hen egg carrier

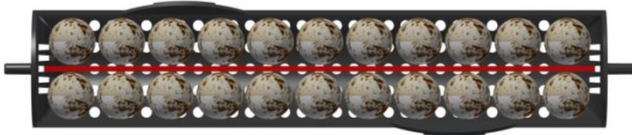

22 quail eggs in optional large egg carrier

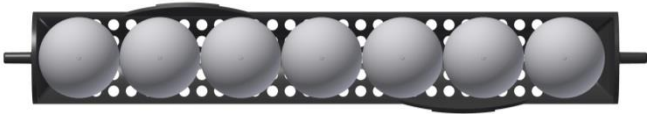

7 duck eggs in hen egg carrier



The large egg carriers are available from brinsea.com or your local stockist (product code AG011).